



Effect of Biochar Application on the Physico-chemical Properties of Ferralitic Soils, Yield and Growth Parameters in Maize Cultivation: A Case Study in Wassande, Adamawa, Cameroon

B. Hamagourdo ^{a*}, A. Sini ^{a,b*}, D. Adoulko ^a, A. Bahouro ^{a,c},
J.C. Fopoussi Tuebue ^a, J.P. Nguetnkam ^a and A. Ibrahima ^d

^a Department of Earth Sciences, Faculty of Science, University of Ngaoundere, P.O Box 454 Ngaoundere, Cameroon.

^b Department of Mining Engineering, School of Geology and Mining Engineering, University of Ngaoundere, P.O. Box 115 Meiganga, Cameroon.

^c Chadian Institute of Agronomic Research for the Development, P.O. Box 5400, Route de Farcha, Njamena, Chad.

^d Department of Biological Sciences, Faculty of Science, University of Ngaoundere, P.O Box 454 Ngaoundere, Cameroon.

Authors' contributions

This work was carried out in collaboration among all authors. Authors BH and AS did the conception and the design of this study, carried out the experimental tests and produced the first draft of the manuscript. Author DA in collaboration with Authors AB and JCFT edited the manuscript and made some observations for its improvement. Authors JPN and AI supervised the work. All authors read and approved the final manuscript.

Article Information

DOI: <https://doi.org/10.9734/ijpss/2025/v37i65517>

Open Peer Review History:

This journal follows the Advanced Open Peer Review policy. Identity of the Reviewers, Editor(s) and additional Reviewers, peer review comments, different versions of the manuscript, comments of the editors, etc are available here: <https://pr.sdiarticle5.com/review-history/136994>

*Corresponding author: E-mail: bhamagourdo23@gmail.com, andrsini@yahoo.com;

ABSTRACT

Biochar is a carbon-rich product obtained from thermochemical conversion of biomass mostly used for soil enrichment. This study aimed to assess soils fertilizing potential of biochar under maize cultivation in Wassande. The physico-chemical properties of the soil and biochar revealed an acidic soil (pH = 5.6) characterized by an average cation exchange capacity (CEC = 11.68 cmol/kg), a moderate sum of exchangeable bases (SEB = 7.5 cmol/kg) and a good saturation rate ($V = 64.45\%$). Furthermore, the analyzed biochar demonstrated a basic pH (9.5), a moderate CEC (29.5 cmol/kg), a low SEB (2.5 cmol/kg) and a high saturation rate ($V = 86.20\%$). The soil incubation with biochar at 10, 20 and 30% improved the nutrient release rate into the soil and performed significant improvement at 20%. Accordingly, at this optimal concentration, the pH values changed from 5.6 to 9.1, 7.8, 9.4 and 8.4, respectively within 1, 2, 4 and 6 months of incubation time. Similarly, the CEC parameter was progressed from 11.68 to 49.88, 21.14, 31.72 and 44.84 cmol/kg within the same treatment period. Thus, the saturation rate values were moved from 64.45% to 56.31%, 74.54%, 32.00% and 61.50%, while the SEB values were changed from 7.53 to 17.33, 15.68, 10.03 and 26.95 cmol/kg at the same periods of incubation. The field tests were performed on three random complete blocks (112.5 m²) with five different treatments: the control (T_{ST}), the treatment with chemical fertilizers (T_{NPK}), the treatment with 20% of biochar at sowing (T_{BS}), at germination (T_{BL}) and at flowering stage (T_{BF}). The results revealed that the soil amended with biochar was more suitable for maize growth and yield, especially when the biochar was applied at germination step. For this treatment, after 8 weeks, the plants reached an average height of 138.61 ± 2.44 cm, with an average of 10.47 ± 0.39 leaves per plant. The plot treated at germination stage showed the best yield (9.64 kg), followed by the plot improved under chemical fertilizers (7.41 kg) while the control soil yield was 5.22 kg. Therefore, these findings demonstrated that biochar is an excellent soil quality regulator, improving soil fertility and could be a versatile alternative to the current use of chemical fertilizers in farming practices.

Keywords: Soil amendment; maize biomass residues; biochar; soil nutrients; yield and growth parameters.

1. INTRODUCTION

In tropical countries, agriculture is the main source of income in the rural sector (Fopoussi et al., 2018). It's mainly subsistence agriculture mostly performed with traditional methods and generally with low yields (Tsafack, 2006). Responding to the demographic explosion, the need to ensure survival in tropical countries is constantly intensifying. The result is an intensive exploitation of land for agricultural purposes leading to acidification and susceptibility to erosion (Tematio and Olson, 1997). This determination has logically led, over the years, to rapid and continuous soil desaturation, with a drastic drop in agricultural yields (Tematio and Olson, 1997, FAO, 2004). Nowadays, the need to restore degraded areas and to preserve those that can be sustained represents a major challenge (Fopoussi et al., 2018, Tematio et al., 2011 and FAO, 2003). The use of petrofertilizers

and biofertilizers, among others, has become an established feature of agricultural practices in tropical countries. Thus, the use of products such as biochar is increasing (Novak et al., 2010 and Bahouro et al., 2023). Due to its adsorption capacity, it constitutes an excellent habitat for microorganisms, particularly bacteria responsible for organic matter decomposition (Thies and Rillig, 2009). Recent studies reported that soil enrichment with biochar favors microorganism activities, good rhizosphere development, reduction of nutrient losses by leaching and, thereby, good plant feeding (Warnock et al., 2007 and Liang et al., 2006). Moreover, the application of biochar into agricultural soils enhances nutrient retention by improving cation exchange capacity (Lehmann, 2009). Indeed, biochar increases soils nitrogen, phosphorus, potassium and total carbon potential. The use of such materials is well suited to tropical soils, which are mostly subjected to leaching

processes (Tematio et al., 2004; Nguetnkam and Dultz, 2011). This is the case of the ferrallitic soils of Adamawa-Cameroon in general, and those of Wassande in particular. These soils are overused by agriculture and become more depleted over the years with an increasingly low pH (Boutrais, 2000). Although petrofertilizers and biofertilizers are alternatives for the enhancement of soil quality, their availability is still a problem to resolve. In the locality of Wassande, maize crops generate a lot of residues, amount 16942 kg/10 ha and after harvest, most of these remain on the land surface until the next season (Hamagourdo, 2019). It is then rightly important to valorize them, and one of the possibilities is to transform them to biochar. This study aimed to assess biochar's potential to improve the physico-chemical properties of the ferrallitic soils of Wassande under maize cultivation.

7°1.44' to 7°7.20' North and longitudes 13°58.32' to 14°7.68' East (Fig. 1) and covers almost 363.57 km². The climate is tropical Sudanian, with two seasons: a dry season of five months, from November to March, and a rainy season of seven months, from April to October (Tchosoua et al., 1998). The annual rainfall is between 1500 to 1700 mm. The average interannual temperatures varied from 20 to 22.5°C. Vegetation consists of shrub savannah, herbaceous savannah and gallery forests alongside watercourses, as well as a few anthropic species. The geology is composed of a basement of metamorphic rocks and granitoids related to the Pan-African orogeny (Tchameni et al., 2006, cited by Nkouandou et al., 2010). The study area is marked by a plateau relief (Saha et al., 2018) on which ferrallitic soils develop, also known as ferralsols according to the World Reference Base classification (WRB, 2015), more or less indurated and enriched with iron and aluminum sesquioxides (Nguetnkam et al., 2002; Feuzeu, 2006). These soils are usually yellowish-red, thick, loose, more or less clayey and porous, nutrient-poor, acidic and very susceptible to erosion (Barkai, 2010; Djoufack, 2011). The period between 1975 and 1989,

2. MATERIALS AND METHODS

2.1 Study Area

The study was carried out in Wassande (Adamawa-Cameroon). It is located at latitudes

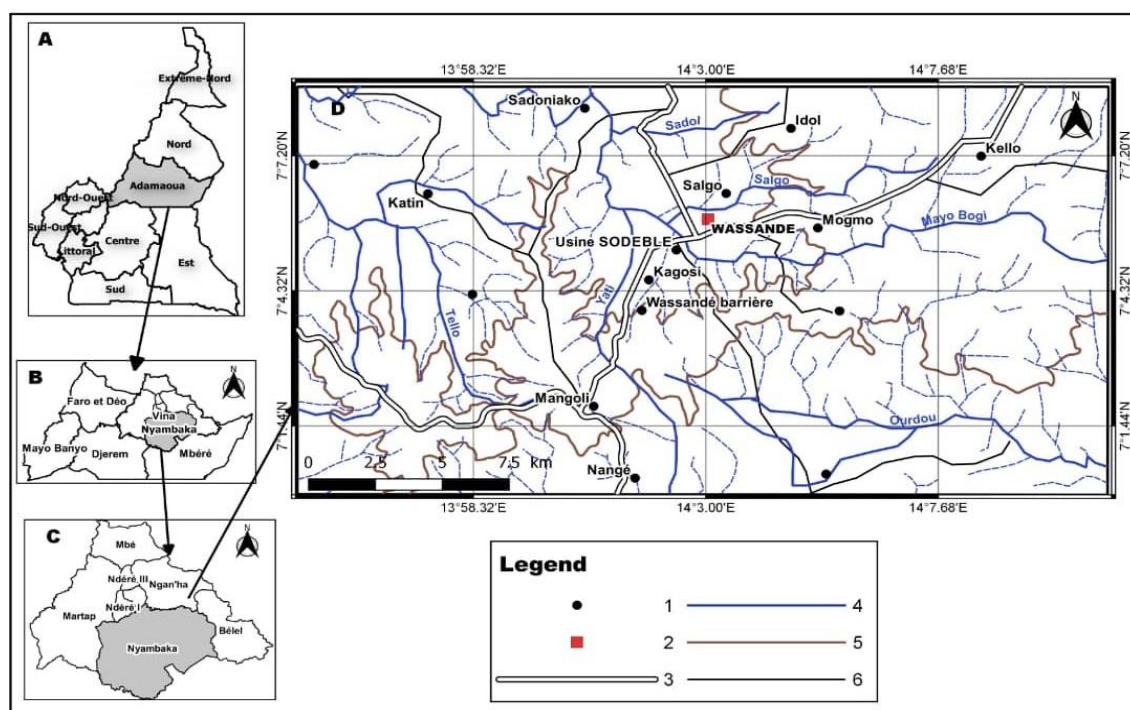

Fig. 1. Location of the study area. **A.** Administrative map of Cameroon indicating the study area in the Adamawa region, **B.** Administrative map of the Adamawa region showing the different divisions, **C.** Administrative map of Vina division indicating the study area, **D.** Map of the study area, 1. Localities, 2. Wassande village, 3. Main Road, 4. Main stream, 5. Curve level, 6. Secondary Road

this area was intensively used for wheat farming, but over the last thirty years, new crops have been introduced. These include groundnuts, potatoes and, most notably, maize, the most widely grown crop.

2.2 Materials

To achieve the objective, this study required: maize residues (stalks, cobs) and the furnace for producing biochar; plastic pots for incubation operations; the shovel for quartering samples, the meter tape for measuring maize growth and yield parameters. The maize seed used for experimental test is the CHH105 (ATP) variety, developed by the Institute of Agricultural Research for Development. This variety has white seeds and a vegetative cycle of 110 to 120 days. Its potential yield is estimated at 5 to 7 tones/ha. NPK (20:10:10) fertilizer and 46%N urea were used for treatments during the field tests.

2.3 Sampling and Analytical Procedures

After selecting the study area for its agricultural potential, the work was conducted in several phases, including field investigations, producing biochar and implementing incubation and field tests. The laboratory analysis completed the work, and the findings were further used for the next experiment.

2.3.1 Field investigations and experimentation design

Following a series of field operations, depleted ferrallitic soil plots were identified. A systematic sampling method was used. A total of 100 samples per plot were taken from three plots belonging to three different sites identified (Fig. 2). Sampling consisted of taking 1 kg of soil at a regular interval of 1 m between sampling points along the upper horizons (0-25 cm). The samples were air-dried, sieved at 2 mm and 110 kg of this fraction were used for the incubation tests.

2.3.2 Production of biochar

The experimental system used for biochar production is a combustion furnace whose main function is to produce biochar from agricultural residues. It includes three parts: a heating chamber with primary and secondary air intakes, four pyrolysis chambers made of steel drums, and a steel roof with a chimney for smoke exhaust. Two tons of maize residues were

calcined at 400°C and 24 kg of biochar removed were sieved to 2 mm for the experimental tests. The different steps of biochar production were illustrated in Fig. 3.

2.3.3 Experimentation design

110 kg of soil collected for the incubation tests were homogenized by quartage to obtain a representative sample. 55 kg of the quartered soil are then quartered to produce two series of tests: A and B (Fig. 4A). Four treatments were applied to each series: the control (T_{ST}) without any addition of biochar, the treatment T_{B10} with 10% of biochar (100 g of biochar per 1000 g of soil), the treatment T_{B20} with 20% of biochar (200 g of biochar per 1000 g of soil) and the treatment T_{B30} with 30% of biochar (300 g of biochar per 1000 g of soil). For field experimentation (Fig. 4B), only the 20% biochar input was considered, as it showed the best trend in element release. Random complete blocks measuring 15 m x 7.5 m (112.5 m²) were used. Five treatments, each repeated three times, are applied: T_{ST} for the control soil (no inputs), T_{NPK} for the soil amended with chemical fertilizers and T_{BS} (at sowing), T_{BL} (at germination) and T_{BF} (at flowering) for the biochar incubation treatments. For the T_{NPK} treatment, 2.4 kg of NPK 20:10:10 fertilizer was applied at germination step and 2.4 kg of urea 46%N at flowering. The maize harvest was carried out after three months.

2.3.4 Analytical procedures

2.3.4.1 Preliminary investigations

Laboratory analyses were carried out at Soil Analysis Laboratory of the Faculty of Agronomy and Agricultural Sciences of the University of Dschang. Fourteen samples were analyzed involving a control soil sample, a biochar sample and twelve incubated soil samples obtained from three treatments (10, 20 and 30% of biochar), with one, two, four and six months of incubation. The physico-chemical parameters investigated are: pH, exchangeable bases (Ca^{2+} , Mg^{2+} , K^+ and Na^+), cation exchange capacity (CEC) and saturation rate (V).

2.3.4.2 Determination of physico-chemical parameters

50 g of sample sieved to 2 mm was used for analysis. pH-water is measured on a soil-water solution at a ratio of 1/2.5 using a pH meter fitted with a glass electrode. Exchangeable bases

(Ca²⁺, Mg²⁺, Na⁺, K⁺) are extracted from the soil with an ammonium acetate solution at pH 7, then measured by atomic absorption spectroscopy and flame emission spectrometry (Anderson and Ingram, 1994). CEC was determined in three phases: saturation of the absorbent complex with the NH₄⁺ ion and extraction of exchangeable

bases; washing of the soil with alcohol to remove the saturating NH₄⁺ solution filling the pores; and determination of NH₄⁺ by Kjeldahl distillation after quantitative desorption with KCl (Anderson and Ingram, 1994). The saturation rate was deduced from the sum of the bases and the total CEC (SEB/CEC* in %) (Anderson and Ingram, 1994).

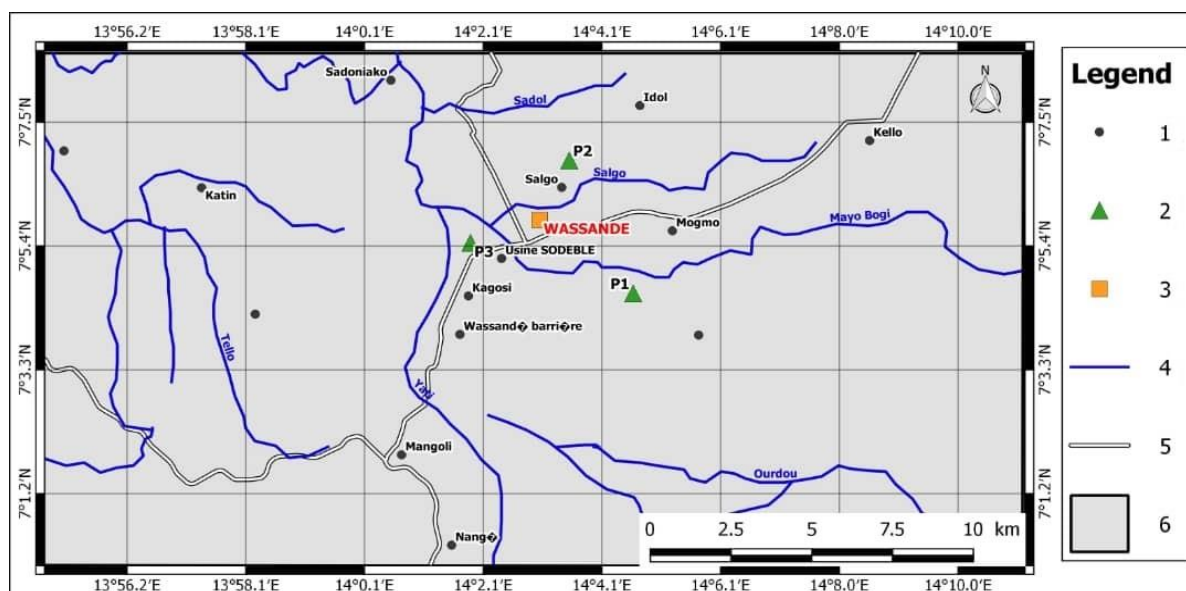

Fig. 2. Sampling map presenting the three sites (P1, P2 and P3). 1. Locality, 2. Sampling site, 3. WASSANDE village, 4. Stream, 5. Road, 6. Delimitation of the study area



Fig. 3. Different steps of biochar production. A. Maize residues, B. Experimental system, C. Biochar produced, D. Fraction sieved at 2 mm to be used for incubation

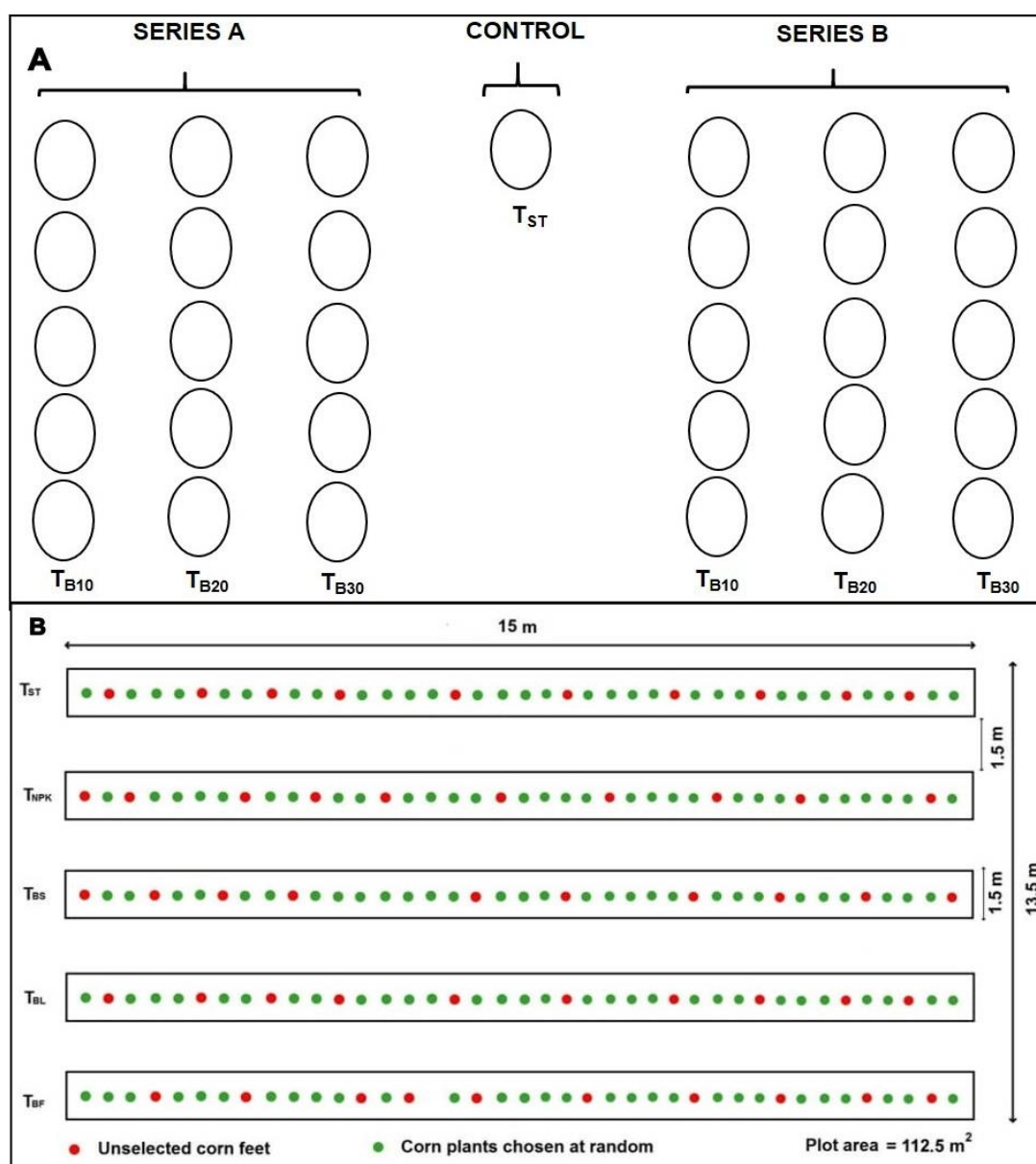

Fig. 4. Experimental system: A. Incubation test including two series of three treatments: the treatment with 10% (T_{B10}), 20% (T_{B20}) and 30% (T_{B30}) of biochar plus a control (T_{ST}), B. Field investigations in a random block involving five treatments: the control (T_{ST}), the treatment with chemical fertilizers (T_{NPK}), the treatment by applying biochar at sowing (T_{BS}), at germination (T_{BL}) and at flowering phases (T_{BF})

The coefficient of relative richness (CRR) of calcium, magnesium and potassium was calculated on the basis of the rate of each element in the sum of bases, related to the value of the optimal Ca/Mg/K balance, which is 76/18/6.

2.3.5 Data analysis

Programs such as Excel and XLSTAT 2022 were used to process data and generate the various graphs. Different maps were generated using

Argis 10.8 and Qgis 1.18 software. The correlation matrixes were generated using Isatis Neo 2021.

3. RESULTS

3.1 Morphology and Physico-chemical Properties of Wassande Soils

The studied soils belong to the ferralitic soil group, formed on basaltic materials and moderately differentiated. Their field

characterization demonstrated that they are brown in color, polyhedral in structure and clayey-sandy in texture. They are generally characterized by the horizons dark brown to red in color associated with nodules and rock fragments. The results of the soil sample analyzed (Table 1), showed an acid pH (5.6), an average CEC (11.68 cmol/kg), a moderate SEB (7.5 cmol/kg) and an average saturation rate (64.45%). Organic matter (OM) was 3.90 cmol/kg and total nitrogen (Nt) 0.5 cmol/kg.

3.2 Evolution of Physico-chemical Properties with the Addition of Biochar

The input of biochar modified the physico-chemical properties of the soil (pH, CEC, SEB and V). Moreover, these parameters significantly changed after incubation at 10, 20 and 30% of biochar (Table 2).

3.2.1 Effect of biochar application on soil pH

Studied soils displayed an acidic pH, while the biochar pH was basic. After incubation, this pH varied, depending on incubation time and the amount of biochar applied (Fig. 5A). Indeed, after one-month of incubation period, it was positively modified for all treatments, with pH values of 7.5±0.93 at 10%, 9.1±1.51 at 20% and 9.6±1.78 at 30% of biochar. The pH values obtained after two months of incubation were 7.9±0.93, 7.8±1.51 and 9.5±1.78 respectively for the 10, 20 and 30% assays. After 4 months incubation, soil pH values were also changed: 7.7±0.93 at 10%, 9.4±1.51 at 20% and 9.8±1.78 at 30%. Soil pH after 6 months incubation also increased for all treatments. Thus, the recorded pH values were 7.5±0.93; 8.4±1.51; and 9.3±1.78 respectively at 10, 20 and 30% of biochar applied.

3.2.2 Effect of biochar application on cationic exchangeable capacity (CEC)

The studied soils depicted a CEC of 11.68cmol/kg whereas biochar had a CEC of 29.5 cmol/kg. After the incubation of biochar, CEC changed for all treatments and according to

incubation time (Fig. 5B). After one month of incubation, all treatments showed a significant increase in CEC. For the 10% dosage, the CEC is 38.88±11.27 cmol/kg. At 20%, it increased slightly (CEC = 49.88±15.93 cmol/kg) and decreased relatively at 30% of biochar (28.86±19.52 cmol/kg). After two months of incubation, for all applied dosages, the CEC obtained was 29.84±11.27 cmol/kg for the 10% treatment, 21.14±15.93 cmol/kg for 20% and 24.32±19.52 cmol/kg for the 30% biochar treatment. After 4 months of incubation, CEC increased steadily with biochar proportion increase. For the 10% treatment, it was 29.04±11.27 cmol/kg, at 20%, 31.72±15.93 cmol/kg and at 30%, 32.72±19.52 cmol/kg. After 6 months of incubation, CEC increased significantly for all treatments, and proportionally to the amount of biochar applied. The 10% treatment recorded 39.62±11.27cmol/kg, the 20% treatment 44.84±15.93 cmol/kg and the 30% treatment 64.28±19.52 cmol/kg.

3.2.3 Effect of biochar application on sum of exchangeable bases (SEB)

Analysis results revealed that the sum of exchangeable bases for the control (SEB= 7.5 cmol/kg) was three times greater than the biochar's sum of exchangeable bases (SEB= 2.5 cmol/kg). This value varied with time and according to the dose of biochar added (Fig. 5C). After one month incubation, the SEB increased significantly for all treatments. At 10%, it was 18.21±7.77 cmol/kg, at 20%, 17.33±7.55 cmol/kg and at 30%, 18.53±13.91 cmol/kg. After two months, the values for the SEB recorded were 16.01±7.77 cmol/kg, 15.68±7.55 cmol/kg and 15.95±13.91cmol/kg, respectively for 10, 20 and 30% dosages. After 4 months incubation, the SEB increased for all treatments compared with the control soil (7.53 cmol/kg). At 10%, SEB = 8.89±7.77 cmol/kg; 10.03±7.55 cmol/kg at 20% and 14.12±13.91 cmol/kg at 30%. The SEB increases significantly for all treatments at 6 months incubation. For the 10% treatment, SEB = 26.59±7.77cmol/kg is recorded, for the 20% treatment, SEB = 26.95±7.55 cmol/kg and for the 30% treatment, SEB = 43.77±13.91 cmol/kg.

Table 1. Physico-chemical parameters analyzed

Parameters	pH	Ca ²⁺	Mg ²⁺	K ⁺	Na ⁺	S	CEC	OM	V	Nt
		cmol/kg							%	
Biochar	9.50	0.10	0.01	2.24	0.15	2.50	29.50	77.77	86.20	0.55
Control soil	5.60	4.96	2.08	0.34	0.15	7.53	11.68	3.90	64.45	0.50

Table 2. Variation of physico-chemical parameters depending on the period and the rate of biochar applied

Incubation time in months		0 month	1 month	2 months	4 months	6 months	
Parameters	ST	BM1-10	BM2-10	BM4-10	BM6-10	SD	
	Treatment at 10%	Ca ²⁺ (cmol/kg)	4.96	7.76	8.42	2.58	9.40
Mg ²⁺ (cmol/kg)		2.08	2.48	4.36	1.52	3.80	1.19
K ⁺ (cmol/kg)		0.34	6.70	2.77	3.15	12.26	4.63
Na ⁺ (cmol/kg)		0.15	1.27	0.46	1.34	1.43	0.58
SEB (cmol/kg)		7.53	18.21	16.01	8.59	26.59	7.77
CEC (cmol/kg)		11.68	38.88	29.84	29.04	39.62	11.27
V (%)		64.45	47.44	56.90	29.50	69.50	15.81
pH		5.60	7.50	7.90	7.70	7.50	0.93
Parameters	ST	BM1-20	BM2-20	BM4-20	BM6-20	SD	
	Treatment at 20%	Ca ²⁺ (cmol/kg)	4.96	6.96	8.44	2.20	5.20
Mg ²⁺ (cmol/kg)		2.08	2.08	4.12	1.00	2.40	1.13
K ⁺ (cmol/kg)		0.34	5.66	2.67	4.84	17.63	6.70
Na ⁺ (cmol/kg)		0.15	2.63	0.45	1.99	1.72	1.05
SEB (cmol/kg)		7.53	17.33	15.68	10.03	26.95	7.55
CEC (cmol/kg)		11.68	49.88	21.14	31.72	44.84	15.93
V (%)		64.45	56.31	74.54	32.00	61.50	15.86
pH		5.60	9.10	7.80	9.40	8.40	1.51
Parameters	ST	BM1-30	BM2-30	BM4-30	BM6-30	SD	
	Treatment at 30%	Ca ²⁺ (cmol/kg)	4.96	4.96	6.36	2.48	6.40
Mg ²⁺ (cmol/kg)		2.08	1.68	1.96	1.02	2.60	0.58
K ⁺ (cmol/kg)		0.34	8.41	6.90	7.31	31.54	11.96
Na ⁺ (cmol/kg)		0.15	3.48	0.72	3.31	3.23	1.61
SEB (cmol/kg)		7.53	18.53	15.95	14.12	43.77	13.91
CEC (cmol/kg)		11.68	28.68	24.32	32.72	64.28	19.52
V (%)		64.45	80.25	67.80	43.00	68.50	13.57
pH		5.60	9.60	9.50	9.80	9.30	1.78

ST = control, BM1-10 = incubated sample at 10% after one month, BM2-20 = incubated sample at 20% after two months, BM4-30 = incubated sample at 30% after four months, BM6-30 = incubated sample at 30% after six months, SD = Standard Deviation

3.2.4 Effect of biochar application on saturation rate (V)

The saturation rate of the control soil is lower than that of the biochar (64.45% <86.20%). Fig. 5D depicted the variation in saturation rate depending on the incubation time and the quantity of biochar added. After one month of incubation, high saturation rate was recorded at 30% treatment (80.25±13.57%), while 10 and 20% treatments (47.44±15.81 and 56.31±15.86% respectively) did not exceed the control values (64.45%). After two months of incubation, saturation rate increased at 20% (74.54±15.86%) and 30% (74.54±13.57%), while it did not outperform the control at 10% (56.9±15.81%). After four months of incubation, there was a significant decrease in saturation rate for all treatments: 29.77±15.81% at 10%, 49.65±15.86% at 20% and 43±13.57% at 30%. After six months, saturation rate increased significantly for all treatments: 107.83±15.81% at 10%, 95.42±15.86% at 20% and 106.28±13.57% at 30% treatment.

3.2.5 Effect of biochar application on growth and yield parameters

Two groups of parameters were studied (Fig. 6): growth parameters (plant height, number of leaves, collar diameter) and yield parameters (cob length, cob diameter, number of grains per cob, number of grain lines per cob, quantity of maize produced per treatment unit). Results after two, four, six and eight weeks for the five treatments (T_{ST}, T_{NPK}, T_{BS}, T_{BL} and T_{BF}) presented in Table 5, revealed that the T_{BS}, T_{BL} and T_{NPK} treatments were more favorable to maize growth than the T_{ST} and T_{BF} treatments. The average maximum height (H_{mm}) of maize plants was reached eight weeks after sowing with H_{mm} = 77.51±1.34 cm for T_{ST}, 105±0.39 cm for T_{NPK}, 121.28±3.29 cm for T_{BS}, 138.61±2.44 cm for T_{BL} and 77.35±0.27 cm for T_{BF}. Regarding the number of leaves, the average number of leaves per maize plant was 8.08±0.42 for the control (T_{ST}), 9.97±0.48 for the soil amended with chemical fertilizers (T_{NPK}), 10.49±0.53 for the treatment of biochar at sowing (T_{BS}), 10.47±0.39 at germination (T_{BL}) and 8.13±0.52 at flowering

(T_{BF}). The maximum collar diameter was 2.27±0.12 cm for T_{ST}, 2.94±0.23 cm for T_{NPK}, 3.35±0.05 cm for T_{BS}, 3.53 ±0.16 for T_{BL} and 2.09 ±0.16 cm for the T_{BF} treatment. Table 6 displayed yield parameters (cob's length, number of grains per cob, quantity produced per plot). It showed the variable average cob length for the different treatments: 10.4±1.33 cm for T_{ST}, 16.1±1.71 cm for T_{NPK}, 15.14±1.64 cm for T_{BS}, 17.39±1.05 cm for T_{BL} and 12.26±0.77 cm for T_{BF}. The average number of lines per cob was 10±3 for T_{ST}, 12.33 ±2.33 for T_{NPK}, 13.66±2 for T_{BS}, 14±2.33 for T_{BL} and 10.33±2.33 for T_{BF}. The average number of maize grains varied from one treatment to another. The treatment of biochar at germination (T_{BL}) revealed the best trend in terms of the number of grains per cob produced (481.97±45.33), followed by T_{BS} treatment (369.8±56.02), T_{NPK} treatment (324.12±54.71), T_{BF} treatment (214.71±32.66) and finally T_{ST} treatment (205.16±33.46). The thousand grains weighted showed similar trend according to the different treatments: 241.01±40.53 g for T_{BL}, 211.53±41.94 g for T_{BS}, 138.81±47.63 g for T_{BF}, 185.32±37.77 g for T_{NPK} and 130.56±37.52 g for the control (T_{ST}). These variations in parameters had an impact on the quantity of maize produced. The yield obtained per treatment for a plot of equal surface area (112.5 m²) was 5.22 kg for the T_{ST} treatment, 7.41 kg for the T_{NPK}, 7.40 kg for T_{BS} treatment, 9.64 kg for T_{BL} treatment and 5.55 kg for the T_{BF} treatment. The treatment of biochar at germination step (T_{BL}) was the most suitable for maize crops, as it provided for better growth and yield parameters.

3.3 Statistical Data Analysis

The variation generated the standard deviations (SD), used to assess the changes observed for each parameter within the soil. The Pearson test revealed linear relationship between the physico-chemical properties of the soil (Table 5) and the yield-growth parameters (Table 6). As showed in Table 2, analysis of the standard deviations (SD) of physico-chemical parameters revealed a differentiated variability according to elements and biochar application rates. Ca²⁺ displayed high relative SD, particularly for the 10 (2.20) and 20% treatments (2.35), indicating a progressive and variable release of this element into the soil. Mg²⁺ showed moderate variability, suggesting a more regular release due to the effect of biochar.

In contrast, K⁺ displayed high SD notably at 30% (11.96), indicating great heterogeneity in its availability, probably linked to its rapid adsorption by the plants and its dynamic interactions with the soil solution. Meanwhile, Na⁺ showed low SD particularly at 10% (0.58), attesting to relative stability and a lesser influence of biochar on this element. CEC showed significant variability, particularly for the 20 (15.93) and 30% treatments (19.52), illustrating the differentiated impact of biochar on soil cation retention. Finally, SEB showed an intermediate dispersion with the high SD at 30% of biochar (13.91), indicating a progressive enrichment in exchangeable cations with biochar. These observations highlight the fact that biochar amendment modifies nutrient dynamics, with more marked effects on the cations essential to soil fertility. This variability justifies the need to optimize doses according to crop needs and intrinsic soil properties, in order to maximize agronomic benefits. Pearson test was used to investigate the correlations between the various parameters and to evaluate the change effect on each other. Variables can be positively correlated when the correlation coefficient is positive or negatively correlated when it is negative. Two correlation matrixes were then obtained: the first (Table 5) highlighted the physico-chemical parameters (pH, Na⁺, K⁺, Ca²⁺, Mg²⁺, CEC, SEB and V), and the second (Table 6) the growth [height of plant (HP), number of leaves (NF) and crown diameter (DT)] and yield parameters [cob's length (LE), cob's diameter (DE), number of grain lines per cob (NLPE), number of grains per cob (NGPE), thousand-grains weighed (P1000G) and total quantity of maize produced (PTP)]. Concerning the correlations between physico-chemical parameters, the results indicated high positive correlation of CEC with Na⁺ (r = 0.92) and a moderate positive correlation with pH (r = 0.78), SEB (r = 0.71) and K⁺ (r = 0.69). SEB revealed high positive relationship with K⁺ (r = 0.91) as well as Na⁺ to pH (r = 0.87) and Mg²⁺ to Ca²⁺ (r = 0.89). The saturation rate presents positive correlation with Ca²⁺ (r = 0.86) and Mg²⁺ (r = 0.88). All the growth and yield parameters present significant positive correlation. Except the correlation between NF and PTP (r = 0.88), all other parameters have their correlation coefficient between 0.9 and 1 (Table 6) proving that almost growth and yield parameters depend on each other.

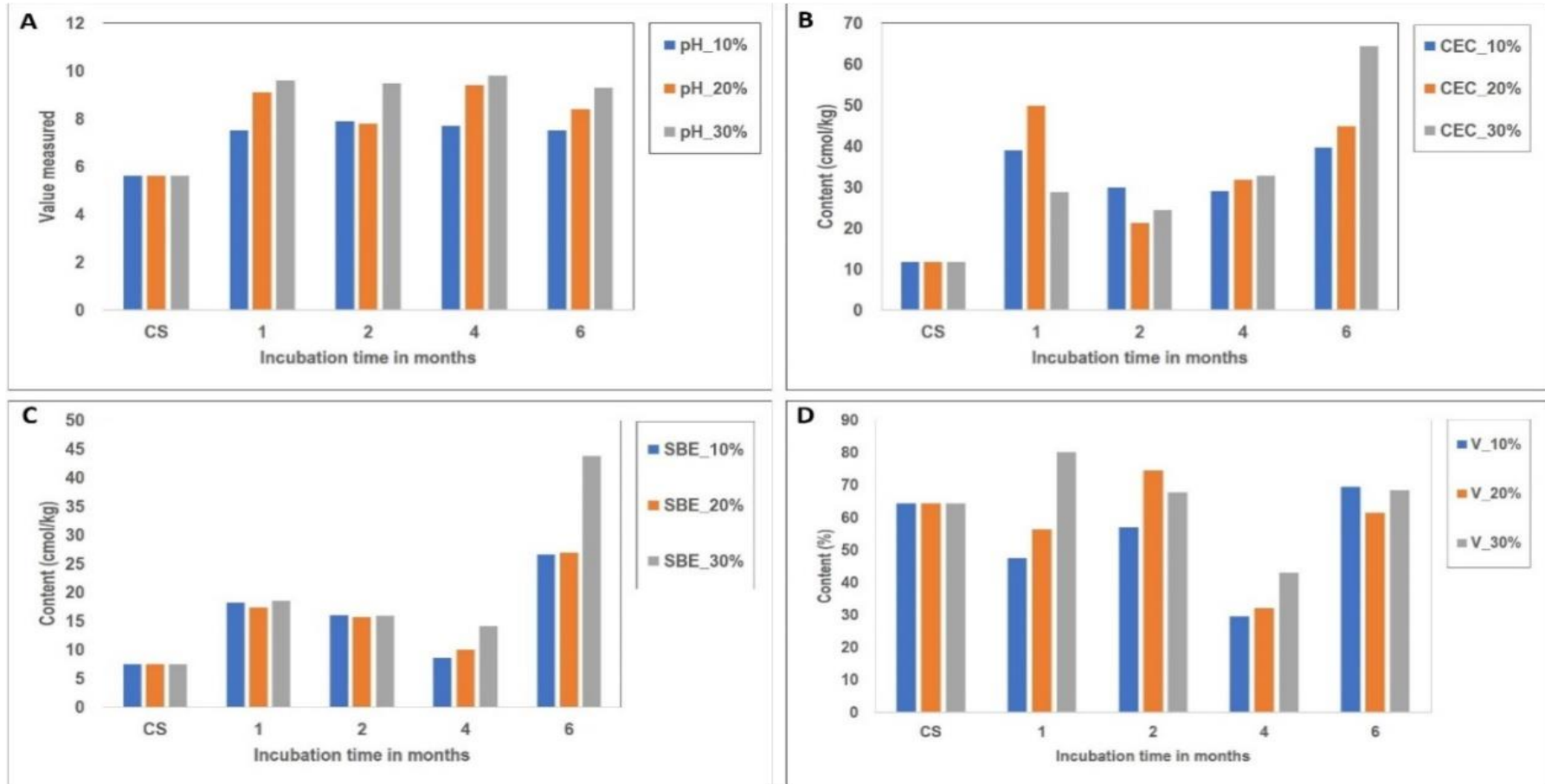

Fig. 5. Variation of physico-chemical parameters per treatment: A. pH; B. Cationic Exchange Capacity (CEC); C. Sum of Exchangeable Bases (SEB) and D. Saturation rate (V)

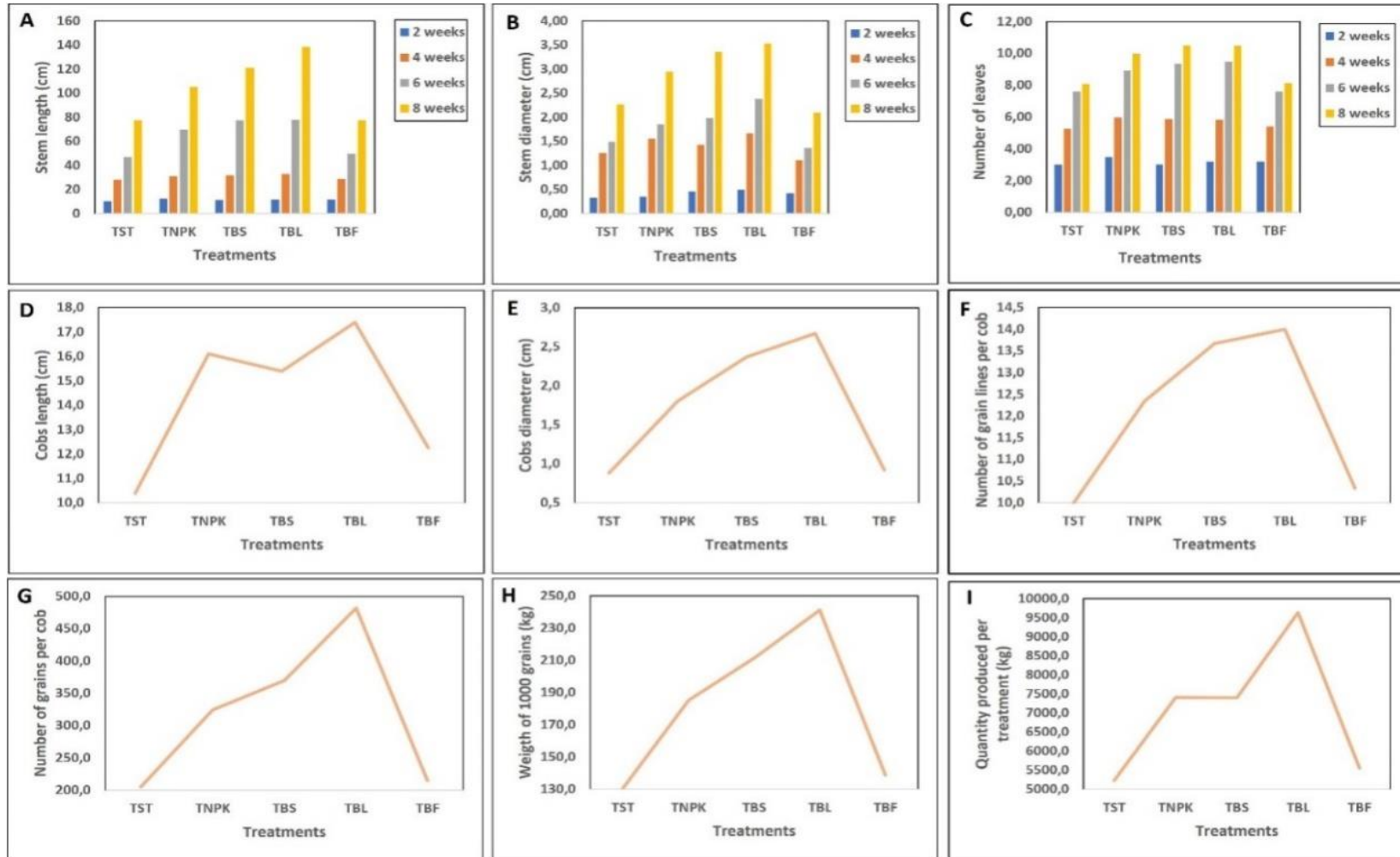

Fig. 6. Variation of growth: A. Stem length, B. Stem diameter, C. Number of leaves and yield parameters: D. Cobs length, E. Cobs diameter, F. Number of grain lines per cob, G. Number of grains per cob, H. Weight of thousand grains, I. Maize quantity produced per treatment

Table 3. Variation of growth parameters depending on the period and the applied treatment

Blocs	Treatment	Plant height (cm)				Number of leaves				Stem diameter (cm)			
		2 SAS	4 SAS	6 SAS	8 SAS	2 SAS	4 SAS	6 SAS	8 SAS	2 SAS	4 SAS	6 SAS	8 SAS
A	T _{ST}	10.15±1.25	28.65±1.34	48.85±0.24	76.65±1.24	3.01±0.21	5.61±0.36	7.31±0.62	8.02±0.56	0.43±0.02	1.30±0.05	1.48±0.12	2.08±0.11
	T _{NPK}	11.52±0.49	32.42±0.53	68.42±2.53	100.42±0.13	3.00±0.43	5.80±0.45	8.80±0.26	9.98±0.55	0.49±0.03	1.49±0.09	1.78±0.23	2.88±0.25
	T _{BS}	10.25±2.34	31.35±3.34	77.35±3.04	114.35±3.24	3.01±0.83	5.51±0.87	9.41±0.27	10.31±0.37	0.72±0.02	1.32±0.10	2.02±0.02	3.32±0.13
	T _{BL}	11.51±3.26	34.41±2.56	78.41±2.36	123.41±2.62	3.03±0.06	5.33±0.46	9.53±0.36	10.13±0.26	0.52±0.01	1.85±0.01	2.35±0.17	3.50±0.16
	T _{BF}	11.55±0.80	29.25±0.40	51.25±0.20	78.65±0.52	3.00±0.80	5.10±0.40	7.70±0.53	8.20±0.62	0.46±0.09	1.20±0.02	1.20±0.02	2.02±0.45
B	T _{ST}	10.75±2.95	27.85±1.25	45.95±1.34	77.25±1.44	2.95±0.02	5.31±0.26	7.61±0.36	8.01±0.36	0.25±0.03	1.03±0.01	1.60±0.05	2.25±0.12
	T _{NPK}	11.52±0.49	29.72±0.69	69.82±0.53	102.32±0.51	3.32±0.49	6.10±0.43	8.90±0.45	10.06±0.45	0.28±0.09	1.29±0.04	1.89±0.09	3.18±0.23
	T _{BS}	12.25±2.34	31.15±2.54	76.35±3.34	118.15±3.30	2.85±0.34	6.05±0.53	9.51±0.27	10.55±0.37	0.34±0.04	1.42±0.02	1.92±0.10	3.42±0.02
	T _{BL}	11.01±2.9	30.61±3.66	77.61±2.56	131.01±2.16	3.51±0.26	6.13±0.05	9.43±0.36	10.53±0.46	0.32±0.02	1.52±0.01	2.25±0.01	3.75±0.17
	T _{BF}	12.05±0.10	27.75±0.90	50.55±0.20	74.05±0.10	3.55±0.80	5.48±0.80	7.10±0.80	8.10±0.40	0.35±0.06	0.96±0.19	1.49±0.08	2.07±0.02
C	T _{ST}	10.45±1.55	28.25±1.35	45.65±0.34	78.65±1.34	3.05±0.10	4.85±0.94	7.88±0.36	8.21±0.36	0.29±0.02	1.43±0.02	1.39±0.09	2.48±0.14
	T _{NPK}	13.12±0.19	30.62±0.49	70.48±2.58	112.42±0.53	4.10±0.43	6.00±0.47	9.02±0.45	9.89±0.45	0.29±0.05	1.89±0.03	1.89±0.07	2.78±0.23
	T _{BS}	11.25±2.14	32.35±1.37	78.39±2.54	131.35±3.34	3.21±0.33	6.01±0.23	9.11±0.87	10.61±0.87	0.31±0.09	1.54±0.02	2.02±0.11	3.32±0.02
	T _{BL}	12.11±0.16	33.21±3.26	77.46±2.36	161.41±2.56	3.05±0.43	6.03±0.02	9.53±0.46	10.77±0.46	0.62±0.02	1.62±0.01	2.55±0.05	3.35±0.17
	T _{BF}	11.35±0.60	28.15±0.60	47.85±0.32	79.35±0.20	3.02±0.50	5.59±0.20	8.03±0.42	8.10±0.54	0.45±0.04	1.16±0.03	1.40±0.06	2.20±0.02

SAS = number of weeks after sowing

Table 4. Variation of yield parameters depending on the period and the applied treatment

Blocs	Treatments	Cobs length (cm)	Lines number per cob	Cob diameter (cm)	Grains number per cob	Weigth of 1000 maize grains (g)	Maize quantity produced (g)
A	T _{ST}	10.80±0.20	10±3	0.85±2	215.33±45.4	131.43±15.50	5257.20
	T _{NPK}	16.5±0.34	12±2	1.50±2	298.56±55.14	185.83±30.07	7433.20
	T _{BS}	16.30±0.33	14±2	2.50±3	368.47±35.08	215.63±20.03	7331.42
	T _{BL}	17.50±0.27	14±2	2.75±3	459.65±12	240.65±40.00	9626.00
	T _{BF}	15.15±0.46	10±3	0.90±2	208.52±32	152.73±34.23	6109.20
B	T _{ST}	10.20±1.37	10±3	0.89±3	198.67±46	129.63±62.28	5185.20
	T _{NPK}	16.38±2.48	12±2	1.95±2	333.18±56	182.93±42.31	7317.20
	T _{BS}	14.47±2.26	13±2	2.62±2	378.39±62	210.31±64.45	7571.60
	T _{BL}	17.42±2.45	14±2	2.54±2	489.43±42	247.04±41.38	9881.60
	T _{BF}	11.61±1.43	10±2	0.90±3	216.20±51	130.86±68.52	5234.40
C	T _{ST}	10.21±2.42	10±3	0.91±3	201.48±49	130.63±34.79	5225.20
	T _{NPK}	15.43±2.31	13±3	1.96±3	340.62±53	187.21±40.94	7488.40
	T _{BS}	14.65±2.35	14±2	1.98±2	362.56±71	208.65±41.34	7302.75
	T _{BL}	17.26±0.45	14±3	2.72±3	496.85±82	235.45±40.23	9418.00
	T _{BF}	10.02±0.42	11±2	0.97±2	219.43±15	132.85±40.14	5314.00

Table 5. Pearson correlation showing the relationship between physico-chemical properties

Ca ²⁺	1.00								
CEC	0.02	1.00							
K ⁺	-0.11	0.69*	1.00						
Mg ²⁺	0.89*	-0.24	-0.07	1.00					
Na ⁺	-0.24	0.92**	0.46	-0.52	1.00				
pH	-0.17	0.78*	0.42	-0.27	0.87*	1.00			
SEB	0.31	0.71*	0.91**	0.29	0.39	0.40	1.00		
V	0.86*	-0.29	-0.05	0.88*	-0.60	-0.58	0.27	1.00	
	Ca ²⁺	CEC	K ⁺	Mg ²⁺	Na ⁺	pH	SEB	V	

*Significant at 0.01 level, **significant at 0.05 level, SEB = Sum of Exchangeable Bases, CEC = Cationic Exchange Capacity, V = Saturation Rate

Table 6. Pearson correlation showing the relationship between growth and yield parameters

DE	1.00								
DT	0.98**	1.00							
HP	1.00**	0.99**	1.00						
LE	0.91**	0.92**	0.90**	1.00					
NF	0.97**	0.98**	0.95**	0.93**	1.00				
NGPE	0.98**	0.96**	0.98**	0.92**	0.91**	1.00			
NLPE	1.00**	0.98**	0.99**	0.92**	0.98**	0.96**	1.00		
P1000G	0.99**	0.98**	0.99**	0.93**	0.95**	0.99**	0.99**	1.00	
PTP	0.94**	0.94**	0.95**	0.94**	0.88*	0.99**	0.92**	0.97**	1.00
	DE	DT	HP	LE	NF	NGPE	NLPE	P1000G	PTP

*Significant at 0.01 level, ** significant at the 0.05 level, HP = Stem length, NF = Number of leaves, DC = Stem diameter, LE = Cob's length, DT = Cob's diameter, NLPE = Number of grain lines per cob, NGPE = Number of grains per cob, P1000G = Thousand-grains weighted, PTP = Maize quantity produced

4. DISCUSSION

The studied soils are very leached and nutrient-poor inducing their low fertility. This would be linked to their overexploitation with nutrients taken by the plants without restitution. They have an acid pH, average CEC and low exchangeable cations content. It should be noted that these are common properties of oxisols in general and those of Ngaoundere in particular (Middelburg et al., 1988). The application of biochar induced a significant pH increase, supporting the conclusions of Lehmann et al., (2003), who reported that biochar generally improves the pH of acidic soils due to the liming effect combined with the carbonate salts in biochar ash. Thus, the application of biochar improved the availability of the soil's nutrients (nitrogen, phosphorus, potassium) for the plant growth and improved crop yield (Glaser et al., 2002; Adekiya et al., 2022; Azuka et al., 2024; Masud et al., 2024; Gehlot et al., 2024). In fact, biochar has a high potential for fertilizing, especially in tropical soils, due to its retention capacity (Glaser et al., 2002) and its high nutrient content (Lehmann et al., 2003). In this work, it is clearly demonstrated that the application of biochar improves the chemical properties of the soils and the crop yield under maize cultivation. The application at germination phase appears to be the best period to improve

elements release into the soil and therefore offers better productivity. Mayola et al., (2017) and Mounirou (2022) have demonstrated that the soil enrichment at germination step, provides more available nutrients for plants. These results are in agreement with the findings of Bahouro et al., (2023) and Ahmadou et al., (2023), respectively in their works on the effect of biochar and compost under maize cultivation in the Sudanian zone of Chad on one hand, and the influence of biochar and powdered rice straw under maize cultivation in northern Cameroon on the other hand. Indeed, biochar enhances the soil's CEC which is an important parameter for determining the soil quality. It represents the total capacity of a soil to hold positively charged cations by electrical attraction. Overall, the CEC of the studied soils is improved in all treatments, promoting the plant's capacity to absorb elements. However, it should be noted that CEC is a parameter closely linked to soil complexes, in particular the clay-humus complex. Thus, CEC in the present study would be specifically linked to the high initial organic matter content of biochar (Liu et al., 2012; Lele, 2016; Bahouro et al., 2023). The behavior of exchangeable bases (Ca²⁺, Mg²⁺, K⁺) and CEC during incubation shows an increase in both base content and CEC which does not depend on the quantity of biochar added. These results are in contrast to

those of Nkouathio et al., (2008), who showed that an increase in both base content and CEC is proportional to the concentration of pyroclastic materials added. The most significant concentrations observed in the amended soils are those of Ca^{2+} , followed by Mg^{2+} and finally K^+ as showed in the works of Nkouathio et al., (2012) and Adoulko (2018). This indicates a significant release of Ca^{2+} and Mg^{2+} from calcined agricultural residues (Nkouathio et al., 2012). The low K^+ concentration can be attributed to its low proportion in residues (Nkouathio et al., 2012; Yaya et al., 2015). In general, the use of biochar to amend soils induces a rapid and significant increase in alkali and alkaline-earth cations content (Ca^{2+} , Mg^{2+} , Na^+ and K^+) which can be explained by their relatively high content in agricultural residues (Nkouathio et al., 2012; Yaya et al., 2015). The increase in exchangeable bases content correlates positively with the increase in CEC, confirming the relationships between these closely related parameters (Nkouathio et al., 2012; Yaya et al., 2015; Adoulko, 2018). The SEB is also significantly improved in all biochar treatments. Overall, contents dropped steadily between the second and fourth months, then increased significantly at the sixth month incubation for all doses. This trend could be explained by external factors such as temperature and humidity. The increase in the SEB, which is a function of exchangeable bases, could be linked to the contribution of biochar containing these chemical elements. It is clearly demonstrated that organic amendments release chemical elements to the soil (Diallo, 2005; Maman and Mason, 2013). The improvement in all these soil chemical parameters is closely linked to an increase in its fertility (Tatuebu, 2018; Adoulko, 2018). The addition of biochar ameliorates the saturation rate but it depends on the incubation time and the quantity of biochar added. The CEC is moderately correlated with K^+ ($r = 0.69$), SEB ($r = 0.71$), pH ($r = 0.78$), but strongly with Na^+ ($r = 0.92$). It has been established that pH has a significant effect on the CEC. The lower the pH, the lower the CEC; the higher the pH, the higher the CEC with the good capacity to hold nutrients. The whole quantity of maize produced per treatment (PTP) is strongly correlated with thousand-grains weighed (P1000G) for each treatment ($r = 0.97$), as well as with the number of lines per cob (NLPE) ($r = 0.92$), cob's length (LE) ($r = 0.94$), cob diameter (DE) ($r = 0.94$) and number of grains produced per cob (NGPE) ($r = 0.99$). The thousand-grains weights measured indicated that

the application of biochar significantly improved grains yield in terms of weight compared to the control. This would be due to the nutrient inputs from the fertilizer materials (Diallo, 2005; Maman and Mason, 2013). It has been demonstrated that the biomass transformation into biochar enhances the plant's soluble nutrients concentration, all of which significantly contribute to the plant's growth and production (Gangil and Wakudkar, 2013; Wang et al., 2028).

5. CONCLUSION

This study investigated the effects of biochar from maize residues on soils chemical properties in Wassande (Adamawa-Cameroon). The summarized results revealed that these soils presented an acidic pH (5.6) with an average CEC (11.68 cmol/kg), a moderate SEB (7.5 cmol/kg) and a good saturation rate (64.45%). The application of biochar at the concentrations of 10, 20 and 30% induced the improvement of the physico-chemical properties and nutrients status of the amended soils compared to the control. Depending on the investigation tests under maize cultivation, the study recommends the application of biochar at germination step for an optimal productivity and crops yield and enhances the use of agricultural residues in farming practices in general and in Wassande in particular. This would reduce the intensive use of chemical fertilizers which are much more harmful to the environment and people's health.

DISCLAIMER (ARTIFICIAL INTELLIGENCE)

Author(s) hereby declare that NO generative AI technologies such as Large Language Models (ChatGPT, COPILOT, etc.) and text-to-image generators have been used during writing or editing of this manuscript.

ACKNOWLEDGEMENTS

The authors thank the Soil Analysis Laboratory of the Faculty of Agronomy and Agricultural Sciences of the University of Dschang who accepts to analyze the samples used for this study.

COMPETING INTERESTS

Authors have declared that no competing interests exist.

REFERENCES

- Adekiya, A. O., Adebisi, O. V., Lower, A. L., Aremu, C., & Ajibade, R. O. (2022). Effects of wood biochar and potassium fertilizer on soil properties. Growth and yield of sweet potato (*Ipomea potato*). *Helion*, 8(11), e11728.
- Adoulko, D. (2018). *Morphologie et évaluation de la reminéralisation des sols de Darang (Adamaoua-Cameroun) par les feldspaths* (Mémoire de Master). Université de Ngaoundéré. 98 p.
- Ahmadou, Y., Simon, B. D., & Nguetnkam, J. P. (2023). Effet du biochar et de la poudre des balles de riz sur la productivité du maïs (*Zea mays*) et les sols au Nord Cameroun. *Afrimed AJ-AI Awamia*, (139), 85–104.
- Anderson, J. M., & Ingram, J. S. I. (1994). *Tropical soil biology and fertility: A handbook of methods* (2nd ed.). CAB International, The Cambrian News, Aberystwyth, United Kingdom. 221 p.
- Azuka, Vincent, C., Eketta, & Oluebube, A. (2024). Biochar particle size contributions to soil chemical properties and nutrient content of degraded Ultisols and plant growth in Nsukka, Southeastern Nigeria. *Discov. Soil*, 1, 3.
- Bahouro, A., Abderamane, H., Djondang, K., Mahamat, N. Z., & Nguetnkam, J. P. (2023). Study of the effect of biochar incubation on some physico-chemical properties of a tropical leached soil from South-West Chad. *Int. J. Plant Soil Sci.*, 35(19), 1840–1851.
- Boutrais, J. (2000). *L'agro-élevage des Foulbés de Ngaoundéré (Adamaoua Camerounais) : les évolutions des relations entre l'agriculture et l'élevage*. CIRAD-Agritrop.
- Diallo, M. D. (2005). *Effet de la qualité des litières de quelques espèces végétales sahéliennes sur la minéralisation de l'azote* (Thèse de doctorat). Université Cheikh Anta Diop de Dakar, Sénégal. 168 p.
- Djoufack, V. (2011). *Étude multi-échelles des précipitations et du couvert végétal au Cameroun : Analyses spatiales, Tendances temporelles, Facteurs climatiques et anthropiques de variabilité du NDVI* (Thèse). Université de Bourgogne, Dijon.
- FAO. (2003). *Les engrais et leurs applications* (4e éd.). Rabat.
- FAO. (2004). *Utilisation des phosphates naturels pour une agriculture durable*. Bulletin FAO Engrais et Nutrition Végétale, 13. Rome.
- Feuzeu, W. M. L. (2006). *Statut minéral des sols des plantes fourragères des eaux d'abreuvement et des bovins du pâturage de Wakwa au Cameroun* (Thèse Doctorat ès Sciences Alimentaires et Nutrition). École Nationale Supérieure des Sciences Agro-Industrielles, Université de Ngaoundéré. 253 p.
- Fopoussi, T. J. C., Basga, D. S., Tematio, P., & Nguetnkam, J. P. (2018). Effect of trachyte powder, human urine and reserved water from cooked beans on Andosols fertility in Cameroon western highlands. *Asian Journal of Soil Science and Plant Nutrition*, 3(2), 17 p.
- Gangil, S., & Wakudkar, H. M. (2013). Generation of biochar from crop residues. *International Journal of Emerging Technology and Advanced Engineering*, 3(3), 566–570.
- Gehlot, Y., Lakaria, B. L., Yadav, S. S., Aher, S. B., Sharma, S. K., Trivedi, S., Kamle, S., Yadav, R., Jadon, P., & Malgaya, G. (2024). Effect of biochar application on performance of rice in a Vertisol of Central India. *Journal of Experimental Agriculture International*, 46(6), 317–322.
- Glaser, B., Lehmann, J., & Zech, W. (2002). Ameliorating physical and chemical properties of highly weathered soils in the tropics with charcoal: A review. *Biol Fertil Soils*, 35, 219–230.
- Hamagourdo, B. (2019). *Morphologie des sols de Mandourou Kolsel et de leur fertilisation par le biochar des résidus de maïs (Adamaoua-Cameroun)* (Mémoire de Master). Université de Ngaoundéré. 91 p.
- Lehmann, J., & Joseph, S. (2009). *Science and technology*. Earthscan. London. 405 p.
- Lehmann, J., Pereira da Silva, J., Steiner, C., Nehls, T., Zech, W., & Glaser, B. (2003). Manure and charcoal amendments. *Plant and Soil*, 249, 343–345.
- Lele, N. B. (2016). *Potentiel d'amélioration de la fertilité des sols sableux et acides de Kinshasa (RDC) par l'usage du charbon des bois (biochar), de la biomasse végétale et des engrais minéraux* (Thèse de doctorat). École Régionale Postuniversitaire.
- Liang, B., Lehmann, J., Solomon, D., Kinyangi, J., Grossman, J., O'Neill, B., Skjemstad, J. O., Thies, J., Luizao, F. J., Petersen, J., & Neves, E. G. (2006). Black carbon

- increases cation exchange capacity in soils. *Soil Sci. Soc. of Am. J.*, 70, 1719–1730.
- Liu, J., Schulz, H., Brandl, S., Miehtke, H., Huwe, B., & Glaser, B. (2012). *J Plant Nutr Soil Sci.*, 175, 698–7.
- Maman, N., & Mason, S. (2013). Poultry manure and inorganic fertilizer to improve pearl millet yield in Niger. *Afr. J. Plant Sci.*, 7(5), 162–1.
- Masud, M. M., Baquy, M. A. A., & Nkoh Nkoh, et al. (2024). Evaluating the potential of different crop straw biochars to capture carbon dioxide and increase the growth of *Zea mays* L. *Discov. Soil*, 1, 13.
- Mayola, M. M., Leyoly, J., & Komanda, J. A. (2017). Effet de l'application du biochar et de la litière d'*Acacia mangium* sur la culture du maïs en alley cropping au plateau de Bateke / RDC. *International Journal of Innovation and Applied Studies*, 19(4), 897–907.
- Middelburg, J. J., van der Weijden, C. H., & Woittiez, J. R. W. (1988). Chemical processes affecting the mobility of major, minor and trace elements during weathering of granitic rocks. *Chemical Geology*, 68, 253–273.
- Mounirou, M. M. (2022). Effet comparé de la fertilisation à base de biochar, engrais organique et engrais chimique sur les éléments minéraux et la production de l'oignon (*Allium cepa* L.). *European Scientific Journal (ESJ)*, 18(24), 47–67.
- Nguetnkam, J. P., & Dultz, S. (2011). Soil degradation in Central North Cameroon: Water dispersible clay in relation to surface charge in Oxisol A and B horizons. *Soil & Tillage Research*, 113, 38–47.
- Nguetnkam, J. P., Kamgan, R., Villieras, F., Ekodeck, G. E., & Yvon, J. (2002). Typology of clays in Vertisols and Fersialitic soils of Northern Cameroon. Communication to the French Clay Group (GFA), Paris, Nov., pp. 17–28.
- Nkouandou, O. F., Ngounouno, I., & Deruelle, B. (2010). Geochemistry of recent basaltic lavas from the North and East of Ngaoundere zones (Cameroon, Adamawa Plateau, Central Africa): Petrogenesis and the nature of the source. *International Journal of Biological and Chemical Sciences*, 4, 984–1003.
- Nkouathio, D., Wandji, P., Bardintzeff, J. M., Tematio, P., Kagou Dongmo, A., & Tchoua, F. (2008). Use of volcanic rocks for the remineralization of ferrallitic soils in tropical regions: Case of basaltic pyroclastics from the Tombel Graben (Cameroon Volcanic Line). *Bulletin de la Société Vaudoise des Sciences Naturelles*, 91(1), 1–14.
- Novak, J. M., Busscher, W. J., & Watts, D. W. (2010). Biochar impact on soil moisture storage in an Ultisol and two Aridisols. *Soil Science*, 177, 310–320.
- Saha, F., Tchio Nkemta, D., Tchindjang, M., Voundi, E., & Mbevo, F. P. (2018). Production of so-called “natural” risks in major urban centers of Cameroon. *Natures Sciences Sociétés*, 26, 418–433.
- Tatuebu, T. F. (2018). *Morphologie des sols de Bandjoun (Ouest-Cameroun) et évaluation du pouvoir fertilisant des basaltes dans la culture du bananier* (Mémoire de Master). Université de Ngaoundéré, Cameroun. 82 p.
- Tchameni, R., Pouclet, A., Penaye, J., Ganwa, A. A., & Toteu, S. F. (2006). Petrography and geochemistry of the Ngaoundere Pan-African granitoids in Central North Cameroon: Implications for their sources and geological setting. *Journal of African Earth Sciences*, 511–529.
- Tchotsoua, M. (2008). *De la spatialisation à l'aide pour un développement maîtrisé en milieu tropical. Le cas des Hautes Terres de l'Adamaoua au Cameroun*. Éditions Manuscrit Université. 249 p.
- Tchotsoua, M., Esoh, E., Mohamadou, G., & Ngana, J. P. (1998). *Diagnostic de l'état de l'environnement de Ngaoundéré et contribution pour une approche de gestion*. In *Proceedings of the Annales de la Faculté des Arts, Lettres et Sciences Humaines de l'Université de Ngaoundéré*, III, 99–144.
- Tematio, P., & Olson, K. R. (1997). Impact of industrialized agriculture on land in Bafou, Cameroon. *Journal of Soil and Water Conservation*, Nov–Dec, 404–405.
- Tematio, P., Kengni, L., Bitom, D., Hodson, M. H. G., & Tsozue, D. (2004). Soils and their distribution on Bambouto volcanic mountain, West Cameroon Highland, Central Africa. *Journal of African Earth Sciences*, 447–457.
- Tematio, P., Tsafack, E. L., & Kengni, L. (2011). Effects of tillage, fallow and burning on selected properties and fertility status of Andosols in the Mounts Bambouto, West Cameroon. *Agricultural Science*, 2(3), 334–340.

- Thies, J. E., & Rillig, M. (2009). Characteristics of biochar: Biological properties. In Lehmann, J., & Joseph, S. (Eds.), *Biochar for environmental management: Science and technology* (pp. 85–105). Earthscan. London.
- Tsafack, E. R. (2006). *Influence de l'activité agricole (labour, écobuage et friche) sur les paramètres de fertilité des sols : Cas des Andosols sur trachytes des Monts Bambouto (Ouest-Cameroun)*. Université de Dschang, Faculté des Sciences. 78 p.
- Wang, L., Xue, C., Nie, X., Liu, Y., & Chen, F. (2018). Effects of biochar application on soil potassium dynamics and crop uptake. *Journal of Plant Nutrition and Soil Science*, 181, 635–643.
- Warnock, D. D., Lehmann, J., Kuyper, T. W., & Rillig, M. C. (2007). Mycorrhizal responses to biochar in soil: Concepts and mechanisms. *Plant and Soil*, 300, 9–20.
- WRB (World Reference Base for Soil Resources). (2015). *International soil classification system for naming soils and creating legends for soil maps*. World Soil Resources Reports No. 106. FAO. Rome.
- Yaya, F., Nguetnkam, J. P., Tchameni, R., Basga, S. D., & Penaye, J. (2015). Assessment of the fertilizing effect of vivianite on the growth and yield of the bean (*Phaseolus vulgaris*) on Oxisols from Ngaoundere (Central North Cameroon). *International Research Journal of Earth Sciences*, 3(4), 18–26.

Disclaimer/Publisher's Note: The statements, opinions and data contained in all publications are solely those of the individual author(s) and contributor(s) and not of the publisher and/or the editor(s). This publisher and/or the editor(s) disclaim responsibility for any injury to people or property resulting from any ideas, methods, instructions or products referred to in the content.

© Copyright (2025): Author(s). The licensee is the journal publisher. This is an Open Access article distributed under the terms of the Creative Commons Attribution License (<http://creativecommons.org/licenses/by/4.0>), which permits unrestricted use, distribution, and reproduction in any medium, provided the original work is properly cited.

Peer-review history:

The peer review history for this paper can be accessed here:

<https://pr.sdiarticle5.com/review-history/136994>